



## EVSE Protocol Controller 2.0 (EPC 2.0)

<http://viridianeV.co.uk>

[info@viridianeV.co.uk](mailto:info@viridianeV.co.uk)

# 1.

# Introduction

## 1.1 ABOUT THIS DOCUMENTATION

### PURPOSE OF THIS DOCUMENTATION

This Manual contains all the information you need for commissioning and using the Viridian EV EPC 2.0. They are intended for use by electrically skilled persons who commission the device.

### SCOPE OF VALIDITY OF THIS DOCUMENTATION

This documentation is valid for all components of the Viridian EV EPC 2.0 specified in this Manual and describes the delivery state as of Feb 2020.

**THIS PRODUCT IS BASED ON THE IEC 61851 AND SAE J1772 INTERNATIONAL STANDARDS**



# 2.

# SAFETY INSTRUCTIONS

## 2.1 CAUTIONS & DANGERS

### **CAUTION: PLEASE OBSERVE THE SAFETY INSTRUCTIONS AND LEGAL NOTES**

Installation requirements for electrical equipment and EVSE vary by country and jurisdiction. It is the responsibility of the installer/user of this product to ensure that legal installation requirements are met. In the UK, this product must be installed and used by a competent and qualified person who will ensure the equipment adheres to the IEE wiring regulations BS7671 (18th Edition or later) and current Building regulations. This device has safety features that enable and help with meeting these regulations.

### **DANGER: VOLTAGE HAZARDS**

Contact with live components can result in serious injuries. Disconnect the system and all devices from the power supply before starting work.

## 2.2 FUSES

### **WARNING: UNDESIRABLE HEAT GENERATION OR FIRE DUE TO INADEQUATE FUSING.**

The internal fuses are designed only to protect the device itself. The system installer and plant operator are responsible for the necessary line protection.

The relay outputs are not fused within the device. Without appropriate protection of the relay outputs, overloading can cause undesirable heat generation or even fire. The relay outputs are to be fused externally by the plant constructor.

## 2.3 REPAIRS

Repairs are not permitted. Defective devices must be disposed of in compliance with environmental requirements.

### **WARNING: DANGERS ASSOCIATED WITH UNAUTHORIZED OPENING OF THE DEVICE**

Unauthorized opening of the device might place the user in danger or result in substantial damage to property.

### **CAUTION: INVALIDATION OF THE MANUFACTURER'S WARRANTY DUE TO UNAUTHORIZED ALTERATIONS TO THE DEVICE**

Alterations to the devices are not permitted. Failure to observe this requirement shall constitute a revocation of the manufacturer's warranty.

# 3.

## DESCRIPTION

### 3.1 OVERVIEW OF THE EPC 2.0

The EPC 2.0 is a DIN rail mounted control module for IEC 61851 compatible EV charge points. Key features include RCM support and PEN Loss detection, helping charge point manufacturers and installers meet regulations in a cost-effective way and protect against electric shock in the unlikely event of an earth and neutral fault problem.

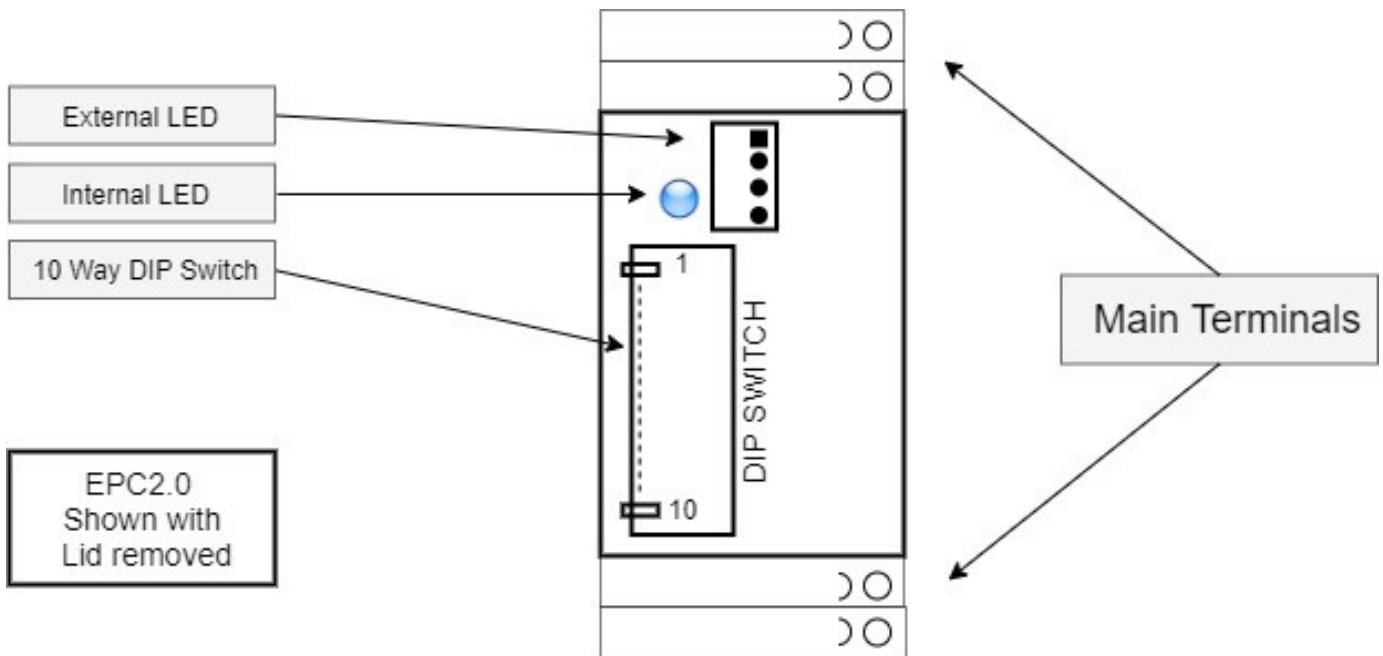

## 3.2 EPC 2.0 FEATURES

DEVICE VERSIONS	<ul style="list-style-type: none"> <li>• The Viridian EV EPC 2.0 has part numbers in this format: EPC20(1)(2)(3). i.e. EPC20 P10-R</li> <li>• (1) indicates the model B = Basic P = Plus</li> <li>• (2) indicates the revision number</li> <li>• (3) Presence of an R indicates supplied with RCM</li> </ul>
SUPPLIED PARTS	EPC 2.0 module, Current Transformer (CT), RCM (when selected; optional part)
AREAS OF APPLICATION & USE	<ul style="list-style-type: none"> <li>• Controlling the charging procedure of electric vehicles in accordance with IEC61851 mode 3</li> <li>• For communication with the electric vehicle according to IEC62196-2 or SAE J1172</li> </ul>
MOUNTING	Mounting onto standard rail according to DIN EN 60715
CONNECTION ELEMENTS	<ul style="list-style-type: none"> <li>• Mains input (207–257V @ 50Hz AC)</li> <li>• 2 Relay contacts (230V AC ) for switching the load and Aux contactor</li> <li>• Solenoid or motor interlock drive for socket (Configuration dependant)</li> <li>• Current Transformer (PEN Loss detection on single phase systems)</li> <li>• Vehicle interface / Signalling contacts</li> <li>• Operating current input (IC) - voltage or resistance</li> <li>• External LED support</li> </ul>
INTEGRATED LED	Displays the operating state of EVSE
Operating Temp	-25 to 50 C
Configurable options	<ul style="list-style-type: none"> <li>• Ability to restrict charging current ( IC ) up to system maximum.</li> <li>• Tethered or Socket outlets</li> <li>• 16A or 32A maximum operating currents depending on fitted system contactor</li> <li>• Solenoid or motor locking systems</li> <li>• Interlock Feedback for status of motorised locks</li> <li>• RCM support enable / disable</li> <li>• Pen Loss enable / disable</li> <li>• Lock engaged polarity</li> </ul>

## 3.3 EPC 2.0 PEN LOSS DETECTION SYSTEM

In the event of a fault in the PEN conductor supplying the property the Protective Earth terminal may become live and as such carry potentially dangerous current.

For **single phase charge points only\*** the EPC 2.0 can protect the user in the event of an open PEN conductor in the power distribution network. In the event of a fault in the PEN conductor the EPC 2.0 will disconnect all conductors including the protective earth conductor.

The device measures earth current (using supplied current transformer (CT)) and voltage (between Live and Neutral); either measurement outside of the factory set limits will cause a fault condition which will cause the EPC 2.0 to open the EV and Aux contactors, isolating the EV and disconnecting all conductors including the PE conductor, meeting minimum requirements in BS 7671: 2018 amendment 1, 722.411.4.1 (iv) and (v).

A single pole isolation contactor with a 240V coil rated for the nominal EVSE load is required to disconnect and isolate PE for this functionality to work.

Details regarding the connections of the EPC 2.0 and the CT can be found in the Terminal Assignment table (6.2) and the Wiring example (6.3)



### Important note: Single phase & 3 phase installations

Full PEN Loss detection functionality in the EPC 2.0 has been designed in accordance with UK specifications (BS 7671: 2018 amendment 1, 722.411.4.1 (iv) and (v)) for **single phase charge points only\***.

The EPC 2.0 complies with paragraph BS 7671:2018 amendment 1, section 722.411.4.1 paragraph (iv) for single phase installations by monitoring the supply voltage. If this is outside of limits (207 - 254 V) the device will open both relay contacts thereby isolating the charge point socket from the mains network, including the earth path.

Additionally, the device complies with paragraph (v) of the above section as the PEN Loss CT is designed to sense this fault current in the earth conductor and open both relay contacts thereby also isolating the charge points socket from the mains network, including the earth path.

It is up to the user creating the EVSE using an EPC 2.0 to understand if it is a single phase or three phase installation and apply the requirements of BS 7671: 2018 amendment 1 accordingly.

It is up to the user creating the EVSE using an EPC 2.0 to know and understand their local regulations outside the UK and whether this device suitably protects against an open PEN conductor situation in the distribution network.

\*If the PEN Loss CT is still connected and PEN Loss is enabled, the device will still open the contactors and isolate the charge point socket for the 3 phase charge points (meeting paragraph (v) of the above specification), however full PEN Loss detection has been designed to meet both paragraphs (iv) and (v) of the above specification and not all live conductors are being measured in a 3 phase charge point by the EPC 2.0.

## 3.4 RCM OPERATION

The EPC 2.0 has a residual current monitor function to monitor currents in the system which protects the system in the event of fault current being detected. The unit is Factory set to trigger at 6mA DC or greater . If this condition arises the EPC 2.0 will disable charging and indicate a fault condition ( see table below ) .

In order to reset the fault state, the EV and the EVSE need to be disconnected and reconnected.

If the fault current is still present then the device will return to a fault state and disable charging. If this persists then consult troubleshooting guide.



**Important note: RCM not installed**

If no RCM device is being used in the EVSE then this functionality needs to be disabled as per the configuration table in this document, reference section ( 4.1. )

## 3.5 SELECTABLE CHARGING CURRENT ( IC )

### **Selecting charging current on installation**

The EPC 2.0 can be configured to restrict the maximum current available to charge the EV on installation of the device . This is achieved by fitting a resistor greater than 100  $\Omega$  ( See 4.2 for more information ) . If the IC resistor is not fitted the EPC 2.0 will default to the maximum current available either 16A or 32A as selected via the DIP switch ,reference section 4.1

### 3.6 FUNCTION APPLICATION EXAMPLE

The following shows a schematic application example of an electric vehicle charge point / EVSE assembled with a EPC 2.0. For example, application option A shows a Type A RCD, an MCB and the 16A / 32A contactor. Application example B shows a RCBO (Type A, C curve) and a 16A / 32A contactor.

In all applications / installations the local wiring regulations must be adhered too.

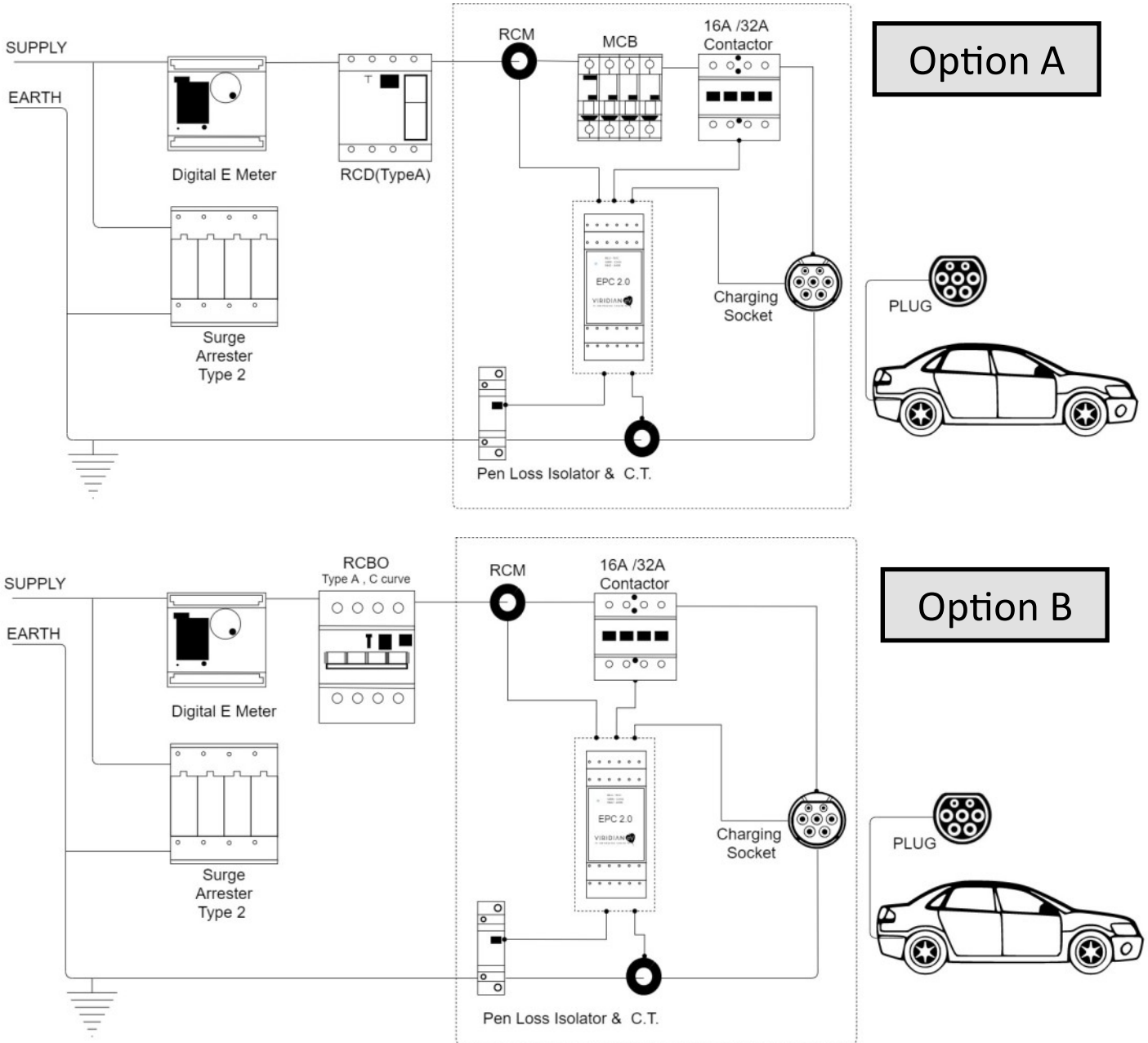

### STATES OF THE CHARGING VEHICLE

- STATE A: Vehicle is not connected
- STATE B: Vehicle connected but not ready to receive energy.
- STATE C: Vehicle is connected/ready to receive energy/no ventilation of the charging area is required in buildings
- STATE D: Vehicle is connected/ready to receive energy but ventilation of the charging area is required in buildings (function not supported by EPC 2.0)
- STATE E: Short-circuit/power supply disconnected from electric vehicle/electricity is not available/other power supply problem
- STATE F: EVSE is not available/other power supply problem



## 3.7 SEQUENCE OF CHARGING PROCESS

### 1. INITIALIZATION

After the operating voltage is applied, the module carries out initializations and function tests indicated by two LED pulsing sequences and then waits for vehicle connection (indicated by pulsing blue LED).

### 2. CHARGING PROCESS

The module waits for a charging cable or vehicle to be connected (state A) indicated by the blue LED continually pulsing. If an approved

connecting cable has been connected (see Proximity) and state B is indicated by the vehicle, the module changes the LED to be steady-blue and activates the interlock. A continuing flashing White LED will indicate that the lock is obstructed if the system has been configured for an interlock.

After interlocking, the charge-enable relays are activated if the vehicle is signalling state C. The charging process is activated, and the LED is changed to steady-green (LED indication : A colour combination is used to indicate the firmware version. The maximum configured charging current is indicated by a series of white pulses) If state D is indicated (ventilation required) then charging and interlock are deactivated as the EPC does not provide a fan-enable mechanism, and the LED is changed to steady-red.

In a fault condition the charge-enable relay and the interlock are deactivated and the LED is changed to continually pulse red. A slowly pulsing RED LED will require no manual intervention to restart charging from a fault condition, once the fault has been identified and cleared. A rapidly pulsing RED LED will require manual intervention.

## VENTILATION REQUIREMENT

### WARNING: SUFFOCATION HAZARD WHEN CHARGING INDOORS

Without ventilation, a danger of suffocation can arise due to gas build-up with some battery types when charging indoors. If the charging process takes place indoors, forced-air ventilation should be installed. The Viridian EV EPC 2.0 does not monitor the functionality of the forced-air ventilation systems and so are not compatible.

### CONTROL PILOT

The pilot circuit is used for the bi-directional exchange of information between the charging station and the vehicle. Via this signal, the charging station indicates to the vehicle the maximum permitted charging current which the vehicle can call up. The operational readiness of the charging station is also indicated. Via this signal, the vehicle indicates to the charging station its current state of charging readiness.

### WARNING

Via the pilot signal, the EPC 2.0 module specifies the maximum charging current that can be drawn by the vehicle. This specified current must be consistent with the line protection configured for the charging device and the rest of the plant configuration. Failure to observe this notice can result in injury to persons or property damage.

### PROXIMITY

With free cable installations the charging device detects the maximum current carrying capacity of the connected charging cable via the proximity signal. The activated charging output coded in the pilot signal is no greater than the current carrying capacity of the charging cable.

The EPC 2.0 is designed to operate with available charging current signals of 16A and 32 A, depending on the current carrying capacity of the cable that is detected. Note : The advertised current from the EVSE maybe downgraded depending on the current carrying capacity of the cable detected. . The charging circuit that is activated must be designed with a suitable line protection for 16A for the installed system. For charging cables that have a current carrying capacity of 32A according to IEC 61851 the system must be designed with a suitable line protection.

# 4.

## Configuration

### 4.1 DIP SWITCH



Configurable features are selected on a 10-way DIP switch located on the top of the EPC 2.0 .The device will be provided with the default configuration of the DIP switch ( see table ) . The Unit will be supplied with the push fit lid to fit after the correct selection for 16A or 32A installation.

This lid can carefully be removed in future by using a small flat blade screwdriver , placing this at the base of the slot and pushing into the device to press in each clips until it releases upward .

DESCRIPTION OF THE 10 WAY DIP SWITCH		
POSITION	OFF ( POSITION UP ) ↑ Supplied Default Setting	ON ( DOWN POSITION) ↓
1	16A Maximum Current	32A Maximum Current
2	Free Socket Outlet	Tethered Cable Outlet
3	Motorised Locking Mechanism	Solenoid Locking Mechanism
4	Lock feedback signal Enabled	Lock feedback signal Disabled
5	Hella Actuator	Phoenix Actuator
6	Residual current monitoring Enabled	Residual current monitoring disabled
7	PEN Loss for single phase systems enabled	PEN Loss for single phase systems disabled *
8	Not Used	Not Used
9	Not Used	Not Used
10	Not Used	Not Used

\* If disabled it will disable charge point if voltage on monitored phase is outside of correct range but will self-recover. If this persists then contact electricity supplier.

## 4.2 INPUT CURRENT TO VEHICLE

### INPUT CURRENT RESISTANCE SELECTION INFORMATION

An Input Current (IC) resistance (or equivalent voltage) restricts the current maximum advertised by the EPC 2.0 and therefore the operating current while charging . The resistor (or voltage) is applied across the IC and 0V terminals. It is recommended to use a resistor of 0.1% tolerance & power rating of 63mW or greater.

The IC values are as described below for either the 16A and 32A systems respectively

#### 16A Installation

Max Current	IC Resistance (Ohms)	IC Equivalent Voltage (V)
16A	348	1.2908
15A	332	1.2462
14A	316	1.2006
13A	301	1.1568
12A	280	1.0938
11A	267	1.0537
10A	249	0.9968
9A	237	0.9580
8A	221	0.9050
7A	205	0.8506
6A	191	0.8018

#### 32A Installation

Max Current	IC Resistance (Ohms)	IC Equivalent Voltage (V)
32A	732	2.1132
31A	698	2.0554
30A	665	1.9970
29A	634	1.9400
28A	619	1.9117
27A	590	1.8553
26A	562	1.7990
25A	536	1.7448
24A	511	1.6909
23A	491	1.6465
22A	475	1.6102

Continued below

Max Current	IC Resistance (Ohms)	IC Equivalent Voltage (V)
21A	453	1.5588
20A	432	1.5084
19A	412	1.4589
18A	392	1.4080
17A	374	1.3610
16A	348	1.2908
15A	332	1.2462
14A	316	1.2006
13A	301	1.1568
12A	280	1.0938
11A	267	1.0537
10A	249	0.9968
9A	237	0.9580
8A	221	0.9050
7A	205	0.8506
6A	191	0.8018

If an IC resistor is **not fitted** the EPC 2.0 will default to the maximum current proclaimed as available determined by the DIP switch of either 16A or 32A

If an IC resistor or less than 100-Ω, MIN, is fitted then the EPC 2.0 will reduce the advertised current capacity to 7A for five seconds after which the EV P1 Contactor and the interlock will be disabled and the EPC 2.0 will enter into a forced Status A until the input current resistance is increased

## 4.3 LED DISPLAY & TROUBLESHOOTING

### LED DISPLAY

The EPC 2.0 has a 3-color LED for displaying operating states and fault conditions. The LED can be lit in blue, green, red, white or purple. The meaning of the individual displays is shown in the following tables:

LED	DESCRIPTION OF OPERATING STATE	
COLOUR	STATUS	
NOT LIT	NOT LIT	The EPC 2.0 is not active, switched off <ul style="list-style-type: none"> <li>No power supply</li> <li>Device defective</li> </ul>
BLUE	PULSING	The EPC 2.0 is waiting for the electric vehicle to be connected to the EVSE (State A)
BLUE	STEADY	Electric vehicle connected, electric vehicle is not ready for charging (State B)
GREEN	STEADY	Charging process active (State C)
WHITE	PULSING	The interlock is activating. If this continues to flash then the lock may be obstructed
RED	STEADY	Electric vehicle requires ventilation, charging deactivated (State D) - EPC 2.0 does not support this functionality so charging discontinued
RED	PULSING	EVSE Fault detected. Charging deactivated (Status F) See Troubleshooting guide.

### GENERAL TROUBLESHOOTING

To test if the EVSE built with the EPC is functioning as intended it is suggested to initiate a charging session and check the operation of the unit by following the sequence below:

- With nothing connected check that EPC LED is flashing blue
- Connect the connector to the vehicle - Check that EPC LED turns to solid blue
- Start a charging session on the vehicle - Check that EPC LED turns green and chosen contactor is energised
- Stop a charging session from within vehicle (Type 2) or by pressing the switch to remove the connector from the vehicle (Type 1) - Check that EPC LED turns to solid blue and contactor is de-energized
- Remove connector from vehicle - Check that EPC LED is now flashing blue

### TROUBLESHOOTING FOR QUALIFIED PERSONNEL ONLY

- Is the EPC and socket/tethered cable correctly earthed? The 0V terminal on the EPC should be connected to Protective Earth in order for the system to operate correctly.
- Ensure all connections in the EVSE are tightened to the correct Torque setting. For M3 terminals on the EPC: 0.6-1.2Nm. Consult relevant manufacturer documentation for other parts used
- Check for correct operation of RCBO & Contactor
- Check for a short between the CP and 0V terminal on EPC

# 5.

# TROUBLESHOOTING

## 5.1 GENERAL TROUBLESHOOTING

LED	DESCRIPTION OF OPERATING STATE	
COLOUR	STATUS	
White	Flashing	lock is obstructed.
Purple	Steady	PEN Loss detected . The EPC 2.0 has disconnected the EVSE . Contact DNO or the utility company responsible for the supply .
Red	Slow Pulsing	State E <ul style="list-style-type: none"> <li>• Communication or Power fault to EV</li> <li>• EVSE Fault—Maintenance or repair required QUALIFIED PERSONNEL</li> </ul>
Red	Fast Pulsing	<ul style="list-style-type: none"> <li>• RCM Fault: 6mA DC current detected</li> <li>• Diode Check Fail</li> </ul>

### TRUBLESHOOTING FOR QUALIFIED PERSONNEL ONLY

Follow commissioning guide to determine the nature of the fault.

- PEN Loss . Contact DNO or the utility company responsible for the supply
- Single Phase monitoring
- Is the EPC and socket/tethered cable correctly earthed? The 0V terminal on the EPC 2.0 should be connected to Protective Earth in order for the system to operate correctly.
- Ensure all connections in the EVSE are tightened to the correct Torque setting. For M3 terminals on the EPC: 0.6-1.2Nm - (factory setting of 1nm). Consult relevant manufacturer documentation for other parts used
- Check for correct operation of RCBO & Contactor
- Check for a short between the CP and 0V terminal on EPC
- Interlock does not action : Check LK FB , LK+ and LK- connections

# 6.

## CONNECTION

### WARNING: UNDESIRABLE HEAT GENERATION OR FIRE DUE TO INADEQUATE FUSING

The internal fuses are designed to offer dual protection only for the device itself. The system installer and plant operator are responsible for the necessary line protection. The relay output control signal is not fused within the device. .

The 16A/32A relay contactor outputs are to be fused externally by the plant constructor. Without appropriate protection of the relay outputs, overloading can cause undesirable heat generation or even fire.

### WARNING: VIA THE PILOT SIGNAL, THE VIRIDIAN EV EPC 2.0 CHARGING CONTROLLER SPECIFIES THE MAXIMUM CHARGING CURRENT THAT CAN BE CALLED UP BY THE VEHICLE.

This specified current must be consistent with the line protection configured for the charging device and the rest of the plant configuration. Failure to observe this notice can result in injury to persons or property damage

### WARNING: THE CONDUCTOR CROSS-SECTIONS MUST BE DESIGNED CORRESPONDING TO A STANDARD-COMPLIANT SYSTEM CONFIGURATION.

The cables that are to be connected must be designed according to the respective type of circuit. Failure to observe this notice can result in injury to persons or property damage.

Depending on the device version the Viridian EV EPC charging controller is connected to the EVSE in the following methods:

## 6.1 CONNECTING TERMINALS & TERMINAL ASSIGNMENT

### TETHERED CABLE

“Tethered” means that the charging cable is permanently connected to the EVSE.. The RCBO should be rated at the maximum current ( 16A/ 32A ) set via the DIP switch ( See Configuration )

### FREE CABLE / SOCKET VERSION

“Free” means that the charging cable is not permanently connected and that the user is expected to provide their own. The EPC 2.0 will energize the 16A or 32A Relay Contactor as selected during installation

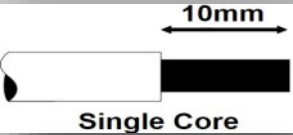
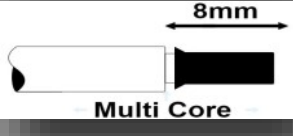
STRIPPED LENGTH	SUITABLE CONDUCTOR CROSS SECTION / AWG	Torque
 <p>10mm</p> <p>Single Core</p>	0,5 ... 2.5 mm <sup>2</sup> / 20-14 AWG	0.5 Nm
 <p>8mm</p> <p>Multi Core</p>	<ul style="list-style-type: none"> <li>Without core ends prepared: 0.5 ... 2.5 mm<sup>2</sup></li> </ul> <p>We advise using 0.25mm<sup>2</sup> bootlace ferrules on smaller gauge wire.</p>	0.5 Nm

### NOTICE

The temperature stability of the cable used must be designed for at least for 75°C. Failure to observe this can result in injury to persons or property damage

## 6.2 EPC TERMINAL ASSIGNMENT

### ALL VERSIONS

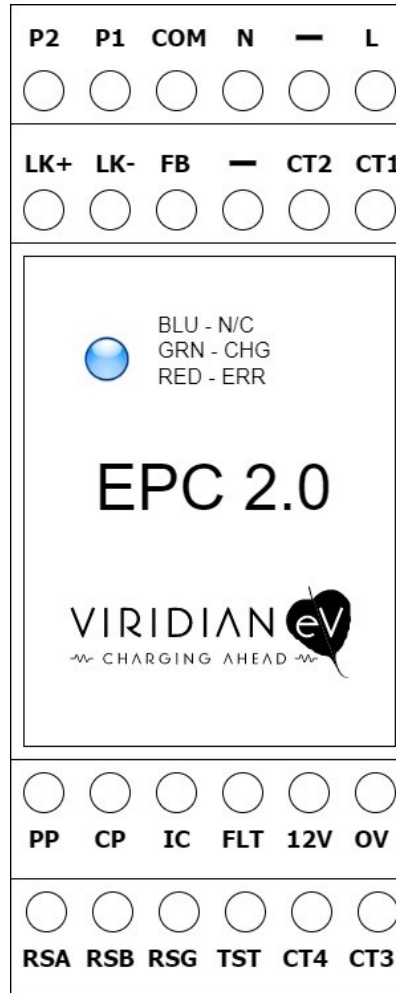

### COMMISSIONING

To test if the EVSE built with the EPC is functioning as intended it is suggested to initiate a charging session and check the operation of the unit by following the sequence below:

- With nothing connected check that EPC LED is flashing blue
- Connect the connector to the vehicle - Check that EPC LED turns to solid blue
- Start a charging session on the vehicle - Check that EPC LED turns green and chosen contactor is energised
- Stop a charging session from within vehicle (Type 2) or by pressing the switch to remove the connector from the vehicle (Type 1) - Check that EPC LED turns to solid blue and contactor is de-energized
- Remove connector from vehicle - Check that EPC LED is now flashing blue



## EPC 2.0 TERMINAL ASSIGNMENT

TERMINAL	DESCRIPTION
L (LINE)	This is where the AC 'live' or 'line' connection is made (207-257V @ 50Hz AC)*
N (NEUTRAL)	This is where the AC 'neutral' connection is made (207-257V @ 50Hz AC)*
OV (PE)	This is where the Protective Earth ( ground ) and 0v connections for the RCM and IC resistor circuits are made*
LK+	Configuration is dependent . <ul style="list-style-type: none"> <li>Provides a drive current to continuously energise the solenoid interlock</li> <li>Provides a drive current to change the motorised interlock state to locked ( The signal is activated for 500ms and changes to pulsed 500ms intervals until the lock is engaged. ( See LK FB )</li> </ul> Rating 12V 300mA
LK-	Configuration is dependent . <ul style="list-style-type: none"> <li>Provides a return path for the solenoid interlock drive current LK+.</li> <li>Provides a drive current to change the motorised interlock state to unlocked ( The signal is activated for 500ms and changes to pulsed 500ms intervals until the lock is disengaged. ( See LK FB )</li> </ul> Rating 12V 300mA
LK FB	If lock feedback has been selected via DIP switch 4
COM	Relay 1 & 2 (common) Live from integrated electrical protection or mains terminals
P1	Relay 1 to coil on the EVSE ( 16A / 32A ) Contactor
P2	Relay 2 to coil on the Auxiliary Contactor
PP ( Proximity Pilot )	Connection for the IEC61851 / J1772 EVSE Connector ( see Proximity )
CP ( Control Pilot )	Connection for the IEC61851 / J1772 EVSE Connector ( see Pilot Circuit )
IC ( Input Current )	The limiting Input Current to the EV , Resistor connection ( The other connection of the Resistor is the 0v (PE) terminal.
12V	12V Supply to provide power to the RCM
FLT	Connects to RCM ' Fault out'. The EPC 2.0 reads if fault condition reported by the RCM
TST	Connects to RCM ' Test' . The EPC 2.0 uses this to check the operation of the RCM before each charging session commences.
CT1 ( PEN)	Connection for current transformer 1; measures earth current for PEN Loss detection (or base load for load sharing in EPC 2.0 + models )
CT2	Connection for the other side of current transformer 1
NC	Not Connected . Not used .
CT3	Connection for current transformer 2; measures EVSE current draw in EPC 2.0 + models (not used in the basic EPC 2.0 models)
CT4	Connection for the other side of current transfer 2
RSA	RS485 connection available in EPC 2.0 + models
RSB	RS485 connection available in EPC 2.0 + models
RSG	RS485 ground connection available in EPC 2.0 + models

- \* On tethered and free cable installations the electrical protection and contactor should be rated according to the maximum current capacity selected via the DIP switch on the EPC 2.0 of either 16A or 32 A

# 6.3 230 V AC POWER SUPPLY

## WIRING EXAMPLE: Socket Outlet

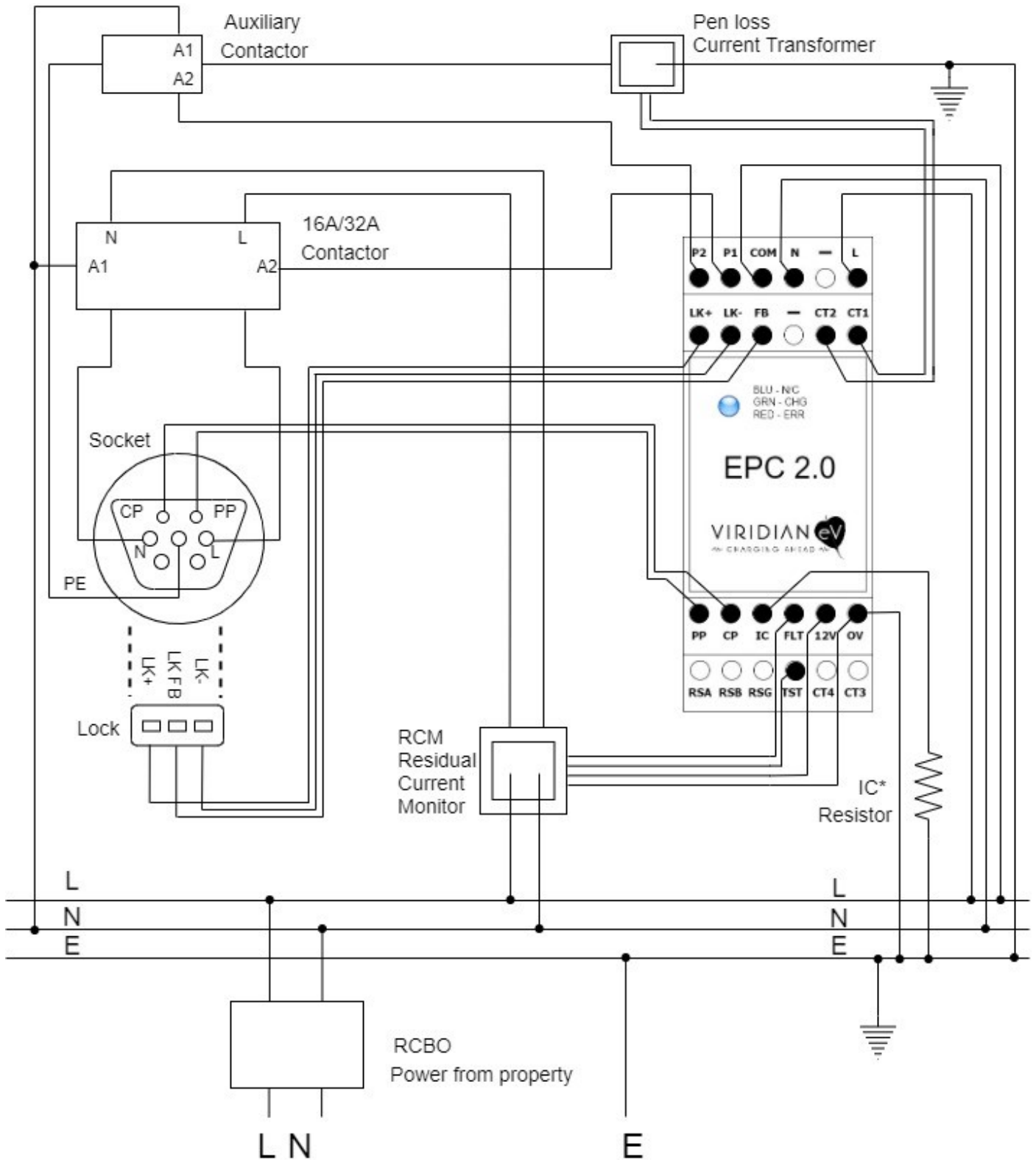

\* Optional fitting : Refer to section 4.2

**WARNING: THE EXTERNAL CONTACT BLOCKS USED MUST BE FLOATING AND SAFELY SEPARATED FROM UNSAFE CIRCUITS.**

Failure to observe this can result in injury to persons or property damage

## 6.4 EXTERNAL LED CONNECTOR

An external RGB LED can be driven by the EPC 2.0. It is 0V active with common 12V. A wiring harness and connector on one end will be an optional extra with the EPC 2.0 that can be cut to length by user and connected to their chosen LED.

### External LED Connector

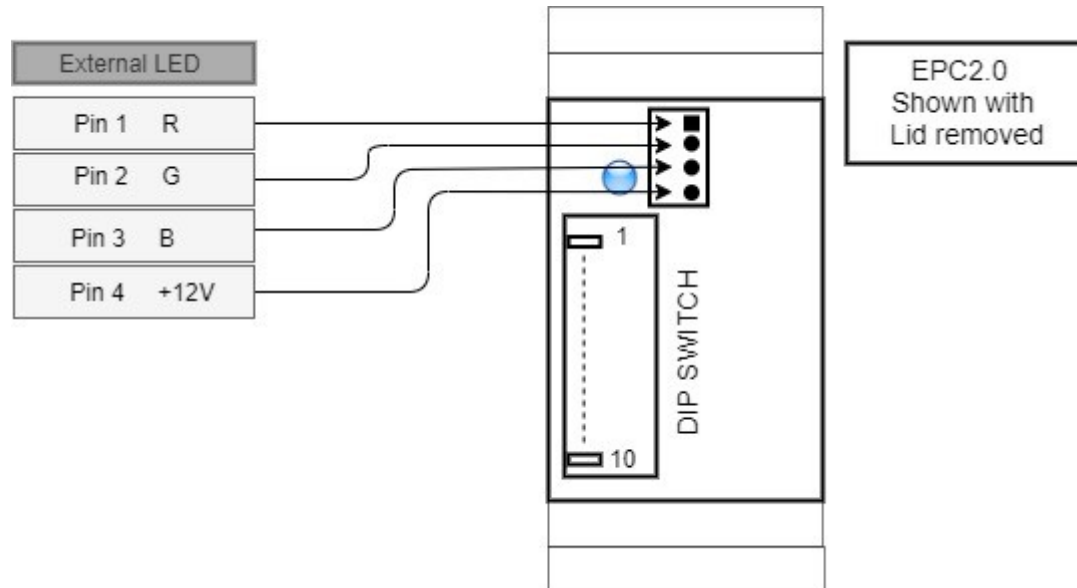

## 6.5 FUNCTIONAL GROUNDING



### VEHICLE INTERFACE ACCORDING TO IEC 61851

1. Connect the terminals "CP" and "PP" (on free cable versions only) directly to the EVSE socket
2. First connect the ground connection of the vehicle interface to the 0V reference point and then route this potential from there

**DANGER: NEVER USE THE TERMINALS OF THE VIRIDIAN EPC 2.0 CHARGING CONTROLLER AS A 0V REFERENCE POINT.**

Always route this externally from the device! The 0V reference point within the plant must be

## 6.6 SHUTDOWN OF POWER BRANCH



According to IEC 61851, a shutdown of the power branch on completion of the charging process within 3 s is required. A shutdown of the power branch on transition from state C to state A is required within 100 ms. The Viridian EPC 2.0 deactivates the relay output within this requirement after detecting the shutdown criterion.

**WARNING: THE SHUTDOWN OF THE POWER BRANCH, IN PARTICULAR THE POWER CONTACTOR, IS TO BE DESIGNED IN SUCH A WAY THAT THE ENTIRE IMPACT CHAIN DOES NOT EXCEED THE REQUIRED 100 MS.**

Failure to observe this notice can result in death or serious physical injury.

# 7.

## MOUNTING

### 7.1 MOUNTING ONTO STANDARD RAIL

1. Clip the device (a) vertically onto the horizontal DIN rail (b).
2. Swing the device downward until the unlocking slider on the DIN rail clicks into place.

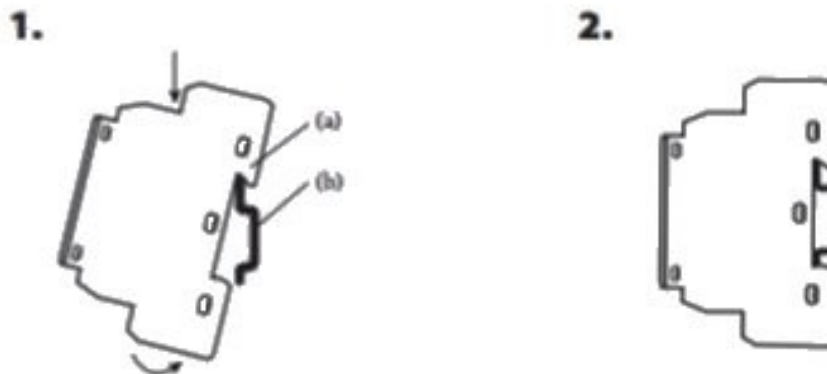

Figure: Mounting onto standard rail

# 8.

## SERVICE & MAINTENANCE

### 8.1 REPLACING THE DEVICE

#### MAINTENANCE

The Viridian EPC 2.0 charging controller is maintenance-free.

**WARNING: THERE ARE NO USER-REPLACEABLE FUSES WITHIN THE EPC**

#### VIRIDIAN EPC 2.0 REPLACEMENT

**REQUIREMENT:** Ensure that the plant and the device itself are de-energized.

#### DANGER: VOLTAGE HAZARDS

Contact with live components can result in serious injuries. Disconnect the system and all devices from the power supply before starting work.

#### PROCEDURE:

1. Disconnect the wiring from all EPC 2.0 connector terminals.
2. Disassemble the device by pulling the locking slider on the back of the device down and swivel the device away from the DIN rail and remove it.
3. Install the new device by clipping the top locking guide onto the DIN rail and swinging it down until the locking slider clicks into place.
4. Reconnect the wiring.
5. Switch on the power supply for the device and the main power for the unit feeder again.

### 8.2 CLEANING

Cleaning of the device is not intended or permissible.

# 7.

## DIMENSIONAL DRAWINGS

