

Juntek VAT4300 (etc) Bi-Directional Wireless Meter User Guide

By Martin Winlow

Note: This guide is not intended to be an authority on the use of this device, nor will reading it replace 3 or more years of hard work becoming an electrical engineer. If you mess up the wiring and burn your house/car/boat to a frazzle, don't blame me! The example application contained here-in involves mains electricity which has the potential to **kill you**, members of your family and any other living creature unfortunate enough to be nearby when everything goes horribly wrong. So unless you are **100% happy that you know what you are doing**, employ a qualified electrician to, at the very least, check your work, if not do it for you.



Please note that for the purposes of the following description, the 'system' is the electronic system that the meter is measuring.

This meter is available from many on-line sources but principally eBay and Amazon – search for 'Wireless Display Meter'. It costs around ~£15-30 and is a very neat package with considerable functionality for the price. I came upon it researching an alternative to the older, clunkier and much more expensive JLD404 meter. The display unit can be bought in a variety of formats to suit the application, eg 'hand-held', panel-mounting etc.

The meter consists of 2 parts; the Measurement Unit (Measurement Unit) and the Display Unit (Display Unit) which can be either wired together with the supplied USB cable (or a longer standard alternative – max distance not known but probably at least 5m depending on the quality of the cable and how electrically noisy the environment is) or used remote to one-another by powering the Display Unit separately from any handy 5-30VDC source or any standard USB socket.

In my experience, it is best to leave the Measurement Unit permanently powered for most reliable use. It uses about 7mA at 12V and twice that with the External Relay Switch 'on'.

1.0 Measurement Unit

This is the main working part of the meter and does all the measuring of all parameters. Unfortunately the case is poorly designed in terms of attaching cables etc and you will probably find that, for heavy current systems, the detachable lid of the Measurement Unit is more useless than useful.

There is a jumper on the top PCB of the Measurement Unit which allows the user to configure the Measurement Unit for either '2-wire' (2W) or '3-wire' (3W) implementation. This relates to the system voltage, where, if it exceeds 30V, the system voltage and Measurement Unit supply must be isolated from each other as the Measurement Unit's max supply input voltage is 30V.

The Measurement Unit has a small transmitter permanently soldered in to the lower printed circuit board (PCB) which sends data to the Display Unit, if the latter is powered, either via the USB cable or wirelessly. The transmitter can be upgraded to a more powerful one which also has an antenna connector for the remote placing of the antenna and thus much enhanced transmission distances. See <https://www.facebook.com/groups/144684286108763/files/> and the file entitled 'Modification to Shunt to take Transmitter and external Aerial v3.pdf' by Peter Clarkson.

It has a large shunt mounted on the top PCB for connecting into the system's load and/or charger circuit.

In order to measure current flowing in *and* out of the battery correctly (in = charging = -ve current flow and out = discharging = +ve current flow), the Measurement Unit must be connected as it is in this example application ie with the left side of the shunt (the side with the green terminal block) going to the battery -ve terminal and the load (and/or charger) on the other shunt terminal...

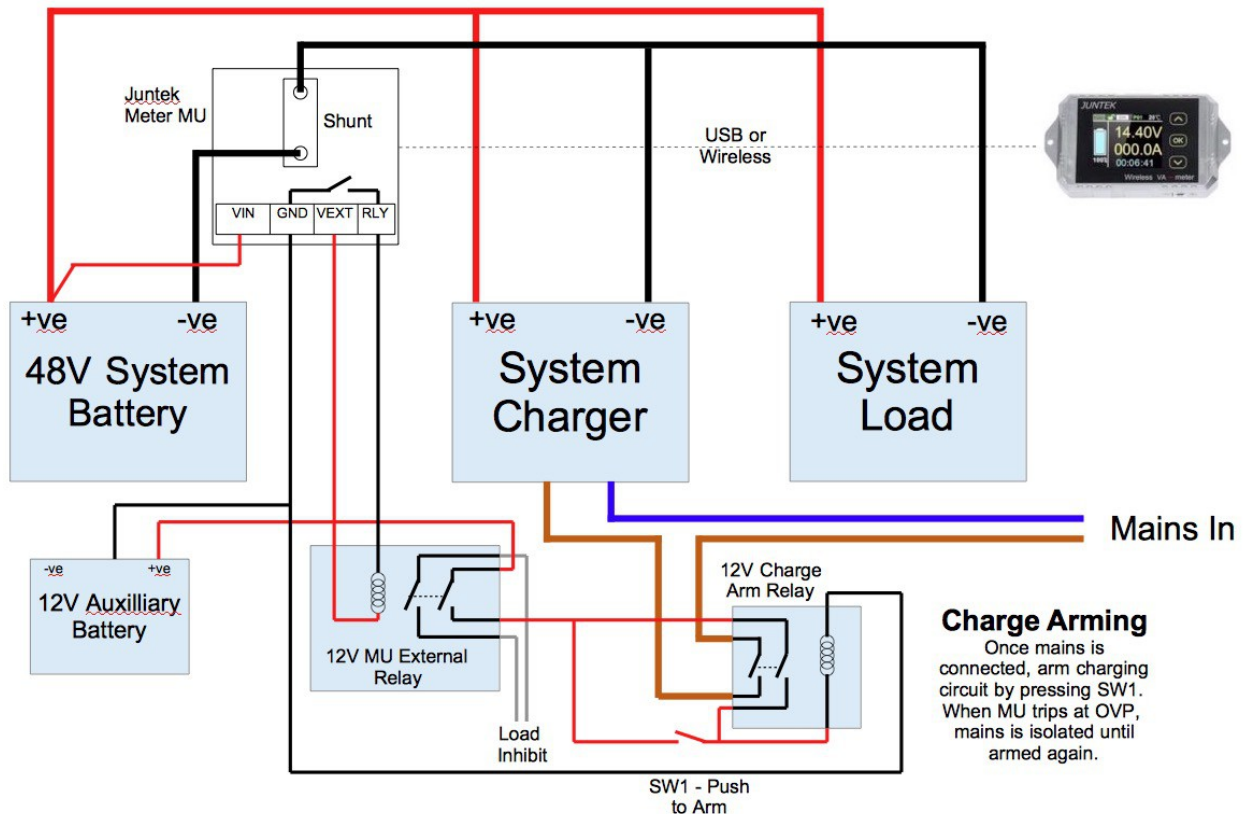

Diagram 1.0 - Example Application

It has a 2 wire connector labeled 'Tsns' for temperature sensor and this can be used with the included temperature sensor which is on a ~1m long lead.

1.2 - It has a 4-way terminal connector at the USB port end whose terminal function descriptions are as follows:-

1.2.1 - VIN (PCB legend: Vin)...

1.2.1.1 - '2W' configuration: The positive connection from the system battery used to power the Measurement Unit. Power used by this connection is about 0.4W. It should be connected to the +ve terminal of the system battery via a 1A fuse.

1.2.1.2 - '3W' configuration: Purely used as a reference for monitoring the system voltage. It should be connected to the +ve terminal of the system battery via a 1A fuse and uses minimal current.

1.2.2 - GND (PCB legend: GND)...

1.2.2.1 - '2W' configuration: Not used.

1.2.2.2 - '3W' configuration: This is the -ve connection for the external meter power supply and grounds the built-in External Relay Switch (see example application diagram above).

1.2.3 - VEXT (PCB legend: Vext)...

1.2.3.1 - '2W' configuration: Not used.

1.2.3.2 - '3W' configuration: This is the +ve connection for the Measurement Unit's power supply and for supplying the External Relay Switch's coil. At 12VDC, the Measurement Unit draws about 8mA from this supply which increases to about 18mA when the External Relay Switch is on (the power used by the external relay itself - if installed - is in addition to this).

1.2.4 - RLY (PCB legend: Rly-). This is the *-ve* connection to an external relay (coil) that can be used by the meter to control the charger and other things and its output goes to ground when the meter's External Relay Switch is turned on in an 'open collector' configuration (ie the External Relay Switch is a transistor not another relay mounted on the PCB). This occurs when either the Display Unit relay status shows 'ON' or any of the following protective states are in effect:- 'NCP', 'OCP', 'LVP', 'OVP' (see 1.2) all of which, if tripped, turn on the External Relay Switch and, therefore, the external relay, if it is connected - *However*, see '2.2.8.3 - Relay Level', below for an inverted operation option.

Where the system voltage does not exceed 30V, the external relay can be powered by the Measurement Unit by simply connecting the +ve side of the coil to the system supply +ve and the -ve side of the relay coil to the 'RLY' terminal.

Where the system voltage exceeds 30V, as in the example in 'Diagram 1.0' above, the external relay must be powered by the VEXT supply and its coil rating should be chosen accordingly. Note that it is not known how much current the meter's External Relay Switch can handle.

There is no hysteresis built-in to the way the relay switch operates (but see section 2.2.8.2 for a 'latching' option setting). In the example of the EV application shown in Diagram 1.0, as soon as the charger brings the battery pack up to the pre-determined 'OVP' voltage, the relay would open, disconnecting the charger from the mains and therefore stopping charging. However, the system battery voltage would immediately start to fall and would therefore turn the relay and charger back on, causing the charger to cycle on and off endlessly. If hysteresis could be programmed in to the device, the charger would not come back on again until the system battery voltage had fallen to some pre-determined level which would, in the case of the example, be a voltage below the fully charged, steady-state pack voltage.

Thus some form of circuit that causes the mains to be permanently disconnected on the first time the External Relay Switch operates would be required. This can be simply arranged by means of a DPDT relay with an 'arm' push-switch (as in the example above).

In the case of low voltage protection ('LVP'), and still referring to the example use diagram 1.0 above, the second set of DPDT relay contacts is wired to inhibit the EV's controller. The 'normally closed' relay contacts could be used instead, if needed. Typically, once triggered, the EV controller would have to be shut down (ignition cycled) before the controller would provide motive power again thereby avoiding the issue of lack of hysteresis.

2.0 Display Unit

2.1 Main Display Screen

When first powered up, the Main Display Screen shows the system's basic, present parameters:- system voltage, system current (+ve for discharging, -ve for charging) and 'on' time in days, hours and seconds (up to 99 days) in a large font. It also shows the mode of display connection (to the Measurement Unit) using an icon; ie wireless, wired (via the USB cable) or 'none', the display control lock status (using a padlock symbol), relay output status ('NCP', 'OCP', 'LVP', 'OVP', 'ON' and 'OFF') a Measurement Unit wireless address code (see 1.2.9), the temperature of the temperature sensor (if attached - otherwise this area of the screen is blank) and system battery state of charge (SOC) by use of a battery icon and %SOC.

2.2 Function Display Screen

When the 'OK' button is pressed, the Function Display Screen is shown for a period that can be set (see

'1.2.8 SET') in 5 second steps up to a max of 60S before it reverts back to the Main Display Screen.

Apart from being able to use the scroll (▲ & ▼) buttons to select a function to adjust, the rest of the Function Display Screen shows:- System volts, system current, system power use (in watts), battery SOC and in the lower portion of the display, shows the energy movement (in and out, cumulatively) since the meter was last cleared (see '2.6 CLR')

2.2.1.0 'NCP' - Negative Current Protection. This can be set from '0' (ie 'off') to -300A depending on the specific meter type. When the current reaches this value the display will indicate 'NCP' and the External Relay Switch will turn on. When the current reduces below the set threshold, the External Relay Switch turns off again. There is a delay setting available (see 1.2.8 'SET' function) allowing momentary (up to 10 seconds) changes of the measured parameter back under the threshold to be ignored, thus delaying reversion back to the normal state. Note: - It is possible, and certainly the manual suggests this is true, that if the 'SET' > 'Relay Level' function (see section 2.2.8.3 below) is set to 'H', the way the delay works may be inverted, ie the turning *off* of the External Relay Switch is delayed for the set time.

2.2.1.1 - Extended functions... On pressing the ▲ button for 2S, a further 3 functions are added to the function list.

2.2.1.2 – 'C-U' – Calibrate Voltage – Used to calibrate the Measurement Unit's voltage measuring ability. The Measurement Unit and Display Unit must be connected by the USB cable for this to work. This is factory set so if you need to do a factory reset, note these before doing so or they will be wiped. The factory setting may be adjusted if needed using the up and down buttons when you highlight 'C-U' by pressing the OK button when the cursor is next to it. Press 'OK' again to save the changes.

2.2.1.3 – 'C-I' – Calibrate Current – As 'C-U'.

2.2.1.4 – 'DFT' – Default Settings (or 'Factory Reset') – Range is 'Y' or 'N'. As it sounds but the Measurement Unit and Display Unit must be connected by the USB cable for this to work. Also, is settings have not be altered you will not be able to select the 'Y' option.

2.2.2 'OCP' - Over Current Protection. This can be set from '0' (ie 'off') to 300A depending on the specific meter type. When the current reaches this value the display will indicate 'OCP' and the External Relay Switch will turn on. The same behaviour is exhibited as for NCP, above.

2.2.3 'LVP' - Low Voltage Protection. This can be set from '0' (ie 'off') to 400V depending on the specific meter type. When the system voltage reaches this value the display will indicate 'LVP' and the External Relay Switch will turn on. The same behaviour is exhibited as for NCP, above.

2.2.4 'OVP' - Over Voltage Protection. This can be set from '0' (ie 'off') to 400V depending on the specific meter type. When the system voltage reaches this value the display will indicate 'OVP' and the External Relay Switch will turn on. The same behaviour is exhibited as for NCP, above.

2.2.5 'OUT'...

1.2.5.1 Press 'OK' to switch the External Relay Switch from its current state to the alternate one (ie either 'on' from 'off' or 'off' from 'on'). The red LED on the Measurement Unit will operate accordingly.

1.2.5.2 Press for 2S to lock or unlock the Display Unit. Press *again* for 2S to *unlock* it.

2.2.6 'CLR' - Resets the meter's displayed accumulated Ah, Wh and the timer to 0.

2.2.7 'BAT'...

2.2.7.1 - 'Set Battery'. This used to configure the battery packs Ah rating from 0 to 6500Ah. This works in conjunction with the monitored energy flow to alter the Display Unit's displayed SOC in both a +ve (discharge) and -ve (charge) direction that makes sense. Obviously, if this parameter is set too high, for example, the SOC will under-represent the actual SOC.

2.2.7.2 - 'AH SETUP'. Range is 0 to 100%. When first installed and switched on, the meter must be told at what approximate SOC the system battery is at so that the Display Unit's SOC makes sense.

2.2.8 'SET'...

2.2.8.1 - 'Start Status'. On or Off. This is the status of the External Relay Switch when the Measurement Unit is powered up. In theory, the Measurement Unit should retain its displayed values when it is powered off (ie when VEXT is reduced below 10V). In practice this does not always happen!

2.2.8.2 - 'Delay Time'. Range 0 to 10S. Once any of the protective functions is triggered and the External Relay Switch is activated, this is the delay before the External Relay Switches back to its prior state. To my mind this should work the other way around – ie it could be used to ignore short (nuisance) protective tripping events. (Please see the note in section 2.2.1 'NCP' as this functionality may be available by setting 2.2.8.3 - 'Relay Level' to 'H'). If set to zero, the External Relay Switch latches ie it does not change back to its prior state on triggering but stays off (or 'on' if inverted – see 2.2.8.3). Thus the user must either 'OK'/'OUT'/'OK' to 're-arm' the protective function or cycle the Measurement Unit power supply (assuming the 'Start Status', 2.2.8.1, is set to 'On').

2.2.8.3 - 'Relay Level' - 'L' or 'H'. If set to 'L' the behaviour of the External Relay Switch is as described above. If set to 'H' the behaviour of the External Relay Switch is inverted ie all the protective functions, if activated, will turn the External Relay Switch *off* instead of on (assuming the External Relay Switch is on already).

2.2.8.4 - 'Disp Chg Time' (Display Change Time). Range: 0 - 60S. Sets the delay before the Function Display reverts back to the Main Display after the 'OK' button (etc) has been operated. If set to zero, when the user presses 'OK' to go to the Function Display, it does not automatically switch back to the Main Display even if the Display Unit's power is cycled. Set the parameter to a positive value again to restart auto-switching to the Main Display.

2.2.8.5 - 'Disp Inverse'. On or Off. Inverts the display (both Main Display Screen and Function Display Screen) colours. This does not affect the power use of the Display Unit.

2.2.9 'ADR'...

2.2.9.1 - The Measurement Unit wireless address can be changed (top right corner of the Function Display Screen). It is factory set to 'A01' (A-zero-1). The basic 'ADR' setting only adjusts the numbers from 1 to 99. This means that one Display Unit can be used with many Measurement Units by adjusting this setting. The letter of the address can also be changed (see '1.2.11 FCH'). As they stand (ie without a means to turn off the Display Unit's transmitter) only one Display Unit can be used with one Measurement Unit. Multiple Measurement Units can, however, be used with one Display Unit by using this addressing function..

2.2.9.2 - If you 'long press' (2S or more) the 'OK' button when 'ADR' is selected, you will turn off the wireless receiver (in wireless mode only ie this is not relevant when the Display Unit is USB-connected to the Measurement Unit) and the Display Unit power must be cycled to turn the wireless receiver back on. When the Display Unit's receiver is off (and it's USB cable is detached), the Display Unit will continue (assuming it has either power via its USB port from a source other than the Measurement Unit or the auxiliary supply port) to function but no data will be received or displayed (cumulative Ah, Wh and the timer will be frozen but the updated details will appear once the Display Unit's receiver is turned back on).

2.2.9.3 - With 'ADR' selected (not highlighted), a 'long press' (2S+) on the DOWN BUTTON (▼) will add 3 further function options to the list on the Function Display Screen screen: 'LNG' (language), 'FCH' (Frequency Channel?) and 'BRI' (Display Unit screen brightness)...

2.2.10 'LNG' - Choose between English (ENG) and Chinese (CHN)

2.2.11 'FCH' - Range A to Z. Adds another 99 x 25 receiver channels for adding more measurement units to the system. Nearby channels do suffer cross-channel interference, though. So leave at least 5 'channels' between addresses.

2.2.12 'BRI' – Range 0 to 15. Display Unit screen brightness. Reducing the brightness of the screen to '0' (it is still visible) reduces the Display Unit power consumption by about half to around 30mA.

2.3 Connections

The display has 2 connectors which are USB (from any standard USB source or any 6V to 30VDC supply). Both are used to power the display only and are alternatives. Obviously in the case of being used wirelessly, the latter means should be used. The display uses approximately 50mA at 12V.

Suggestions for amendments or alterations should be emailed to me at 'm@winlow.co.uk'.

Copyright - EVBitz.uk - 2018.